



SPECIFICATION

CDS-320-TSM-A1

32" All-In-One Touch Screen Monitor

32" PCAP Touch Screens with Dual OS



Dual OS - Windows & Android

Both Android and Windows operating systems are installed on the integrated PC for ultimate flexibility. These displays provide a fully integrated solution - whether your application calls for Android or Windows.



10 Point PCAP Touch

Having up to 10 touch points allows you to manipulate images, zoom in and out as well as perform many other touch gestures; much like you would with a domestic tablet. It also allows for multiple users interacting with the screen at one time.



Surface Plasma Treatment

The oleophobic coating makes the glass front more resistant to oil and water residue left by fingerprint marks and makes touch gestures smoother. Unlike other touch screens the glass is not etched, vastly improving the optical clarity.



None Treated Touch Screen

PCAP Surface Plasma Treated Touch Screen

450cd/m² IPS Panel

Commercial grade IPS technology accurately displays image quality and colour depth with no fall-off in colour accuracy. These panels are designed to achieve ultimate lifelike colour temperature when used in either landscape or portrait.



Conventional Signage Display

PCAP Touch Screen with Dual OS

Other Features

24/7 Commercial Use

These displays use a commercial grade LCD panel and LED backlight. They have the ability to be in constant use 24/7 for over 70,000 hours and have no external buttons or controls to avoid tampering.



Low Power Consumption

The LED backlight technology provides improved brightness and contrast. Their lifespan is drastically improved to over 70,000 hours and the power consumption is reduced by around 30%.

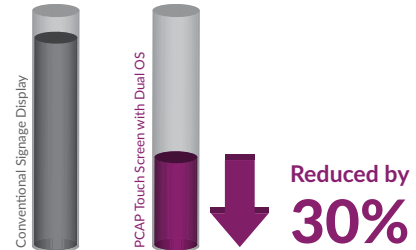

Attach External Devices

If the internal PC is not powerful enough for your application you can connect it to an external source, like a more powerful PC or media player, using HDMI or VGA/3.5mm audio and USB to use the display as a touch screen monitor.

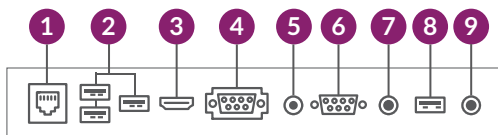

- 1 LAN
- 2 USB x 3
- 3 HDMI
- 4 VGA
- 5 AUDIO IN
- 6 RS-232
- 7 MIC/AUDIO
- 8 TOUCH USB
- 9 AUDIO OUT

Giant Tablet Styling

Their tempered edge-to-edge glass face, rounded corners, super slim profile and aluminium surround all add to the captivating tablet-like aesthetics as well as protecting the internal components from potential damage.

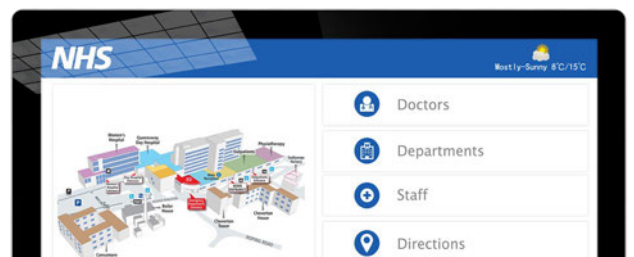

Built In Wi-Fi

As well as having an Ethernet port you can wirelessly connect to the internet thanks to the built in Wi-Fi.



Integrated Speakers

The displays feature two integrated slimline speakers for applications that require an audio element.

2W, 5Ω x 2
Integrated Speakers



Mirror Version

A special version of the PCAP Touch Screen with a mirror finish is available in a 50" model.



Touch CMS

For a small charge you can take advantage of our user-friendly CMS, allowing you to conveniently create your own interactive content.



Key Features



DUAL OS



10 TOUCH POINTS



IPS PANEL



24/7 COMMERCIAL USE



LANDSCAPE OR PORTRAIT ORIENTATION



WIFI AND LAN



LED BACKLIGHT



INTEGRATED SPEAKERS

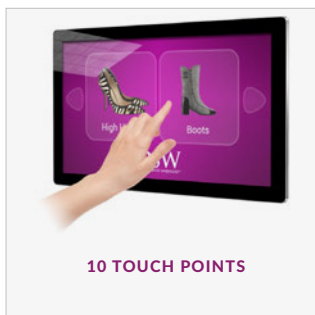

10 TOUCH POINTS



SURFACE PLASMA TREATMENT

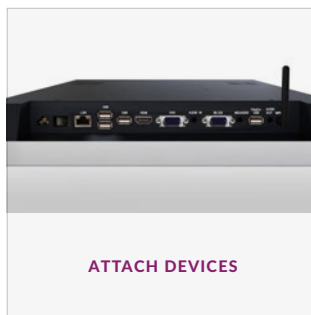

ATTACH DEVICES



GIANT TABLET STYLING

Specification Table

		32 Inch
Panel	Resolution	1920x1080
	Display Area (mm)	701.4x395.8
	Aspect Ratio	16:9
	Brightness (cd/m ²)	450
	Colour	16.7M
	Viewing Angle	178°
	Contrast Ratio	5000:1
Touch	Touch Technology	Projected Capacitive
	Touch Points	10
	Glass Hardness	7H minimum
Audio	Speaker Type	2W, 5Ω (x2)
AV Inputs/Outputs	Inputs (when used as monitor)	HDMI, VGA, RS-232
	Audio Input (when used as monitor)	Audio Socket (3.5mm)
	Audio Output (Internal PC)	Audio Socket (3.5mm)
Power	Power Consumption (W)	52
	Input Voltage	AC110~240V (50Hz~60Hz)
Mechanical	Unit Size (WxHxD mm)	814x504x69
	Package Size (WxHxD mm)	955x630x230
	VESA Holes (mm)	400x200
	Net Weight (kg)	15.25
	Gross Weight (kg)	17.7
Environmental	Operating Temperature	0 °C to 50 °C
	Storage Temperature	-30°C to 60°C
	Operating Humidity	10% to 80%
	Storage Humidity	5% to 95%
Computer	CPU	Intel® Atom™ (Quad-core) x5-Z8350 Processor (2M Cache, up to 1.92 GHz)
	RAM	4GB (DDR3L-RS 1600MHz)
	Instruction Set	64-bit
	Graphic Engine	Intel® HD Graphics 400 (8th Gen, Supports DirectX11.2, OpenGL4.4 and OpenCL 2.0)
	Hard Drive/Internal Memory (eMMC)	64GB
	USB	2 x USB 2.0
	LAN	10/100/1000 Ethernet
	Wi-Fi	802.11b/g/n
	OS	Android 5.1.1 Windows® 8 / 8.1 64-bit, Windows® 10 Pro 64-bit (licence purchased separately)
	Other	No accessible buttons or controls
Accessories	Included	Remote Control, User Manual, Power Cable, USB to USB Cable, Wi-Fi Aerial
	Optional	Wall Mount, Floor Stand/Trolley, Ceiling Mount, Table Stand
Warranty	Warranty Period	3 Year Warranty
	Technical Support	Lifetime

Errors and omissions excepted



Technical Drawing

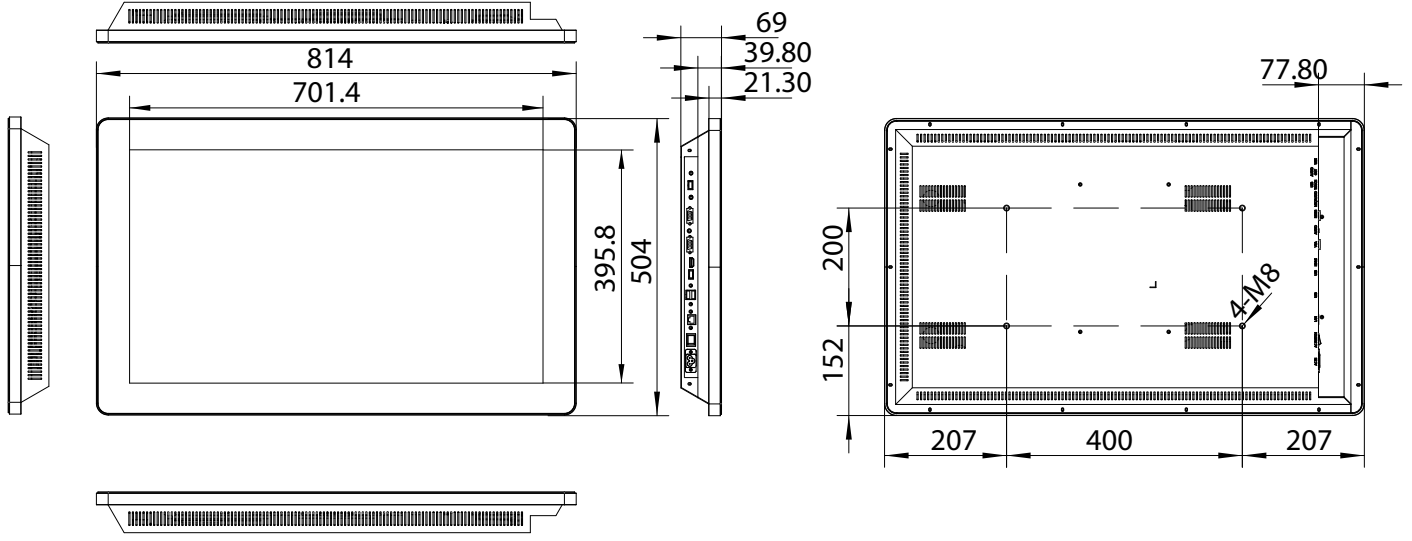

Need any additional information?

If you need any assistance with pricing information, technical support or require any additional information our team would be more than happy to assist.



CONTACT US:

Crystal Display Systems Ltd
Unit 6 M2M Park, Fort Bridgewood,
Maidstone Road,
Rochester,
Kent ME1 3DQ
United Kingdom

T: +44 (0) 1634 791600
E: info@crystal-display.com
W: www.crystal-display.com
www.crystal-digitalsignage.com

GLOBAL SUPPLIER OF DIGIAL SIGNAGE SOLUTIONS

More information can be found at:

www.crystal-digitalsignage.com